

<b>SPEC. INFO</b>	<b>FL-CC0820-5MX</b>	K66886-S001-B13
		Aug. 30. 2019

1. Model FL-CC0820-5MX
2. Application For 2/3 Format Camera

3. Specification

3-1. Physical (As per the attached drawing)

- (1) Dimensions  $\phi 33.0 \text{ mm} \times 43.0 \text{ mm}$
- (2) Weight 78 g
- (3) Mount C-Mount (1 – 32 UN – 2A)
- (4) Filter Screw Size M30.5 mm , P = 0.5 mm

3-2. Optical

- (1) Focal Length 8 mm  $\pm 5\%$
- (2) Max. Aperture Ratio 1: 2.0
- (3) Iris Range F / 2.0 to F / 16
- (4) Angle of View  
 Diagonal 70.1°  
 Horizontal 58.5°  
 Vertical 45.3°
- (5) Picture format 8.8 mm  $\times$  6.6 mm
- (6) Focusing Range Inf. to 0.1 m
- (7) Back Focal Length 13.0 mm (in air)
- (8) Flange Back Length 17.526 mm  $\pm$  0.05 mm (in air)

3-3. Mechanical

- (1) Focusing Mechanism  
 Rotation Angle 56°  
 Rotation Torque 1.0N·cm to 9.0 N·cm  
 Focus Ring can be fixed at any positions by  
 3 fixing screws or 1 thumb screw (refer to external view)
- (2) Iris Mechanism  
 Non-click  
 Rotation Angle 83°  
 Rotation Torque 0.01N·cm to 3.0 N·cm  
 Iris Ring can be fixed at any positions by 3 fixing screws  
 or 1 thumb screw (refer to external view)

3-4. Vibration & Shock Test Standard

(1) Vibration Conditions

Wave	Sine Wave
Acceleration	1.96 m/s <sup>2</sup> to 59.78 m/s <sup>2</sup>
Cycle Range	10 Hz to 55 Hz
Cycle Period	3 Minutes
Duration of Vibration	120 Minutes Respectively in Three Dimensional Directions

(2) Shock Conditions

Tester	Shock Testing Machine by Dropping
Impact Force	588 m/s <sup>2</sup>
Duration of Shock	3.5 ms
Directions & Number of Times	1 Time Respectively in Three Dimensional Directions

<b>SPEC. INFO</b>	<b>FL-CC0820-5MX</b>	K66886-S001-B23
		Aug. 30. 2019

3-5. Environmental Temperature Range       $-10^{\circ}\text{C}$  to  $+50^{\circ}\text{C}$

4. Accessories

- |                                       |          |                      |
|---------------------------------------|----------|----------------------|
| (1) Front Lens Cap                    | 1 piece  |                      |
| (2) Rear Lens Cap                     | 1 piece  |                      |
| (3) Fixing Screw for Focus ,Iris Ring | 6 pieces |                      |
| (4) Thumbscrew for Focus ,Iris Ring   | 2 pieces | (for Optional Usage) |
| (5) Instruction Manual                | 1 sheet  |                      |
| (6) Packing Box                       | 1 piece  |                      |

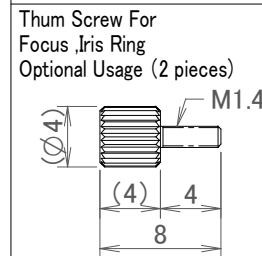
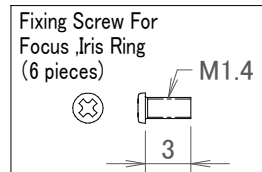
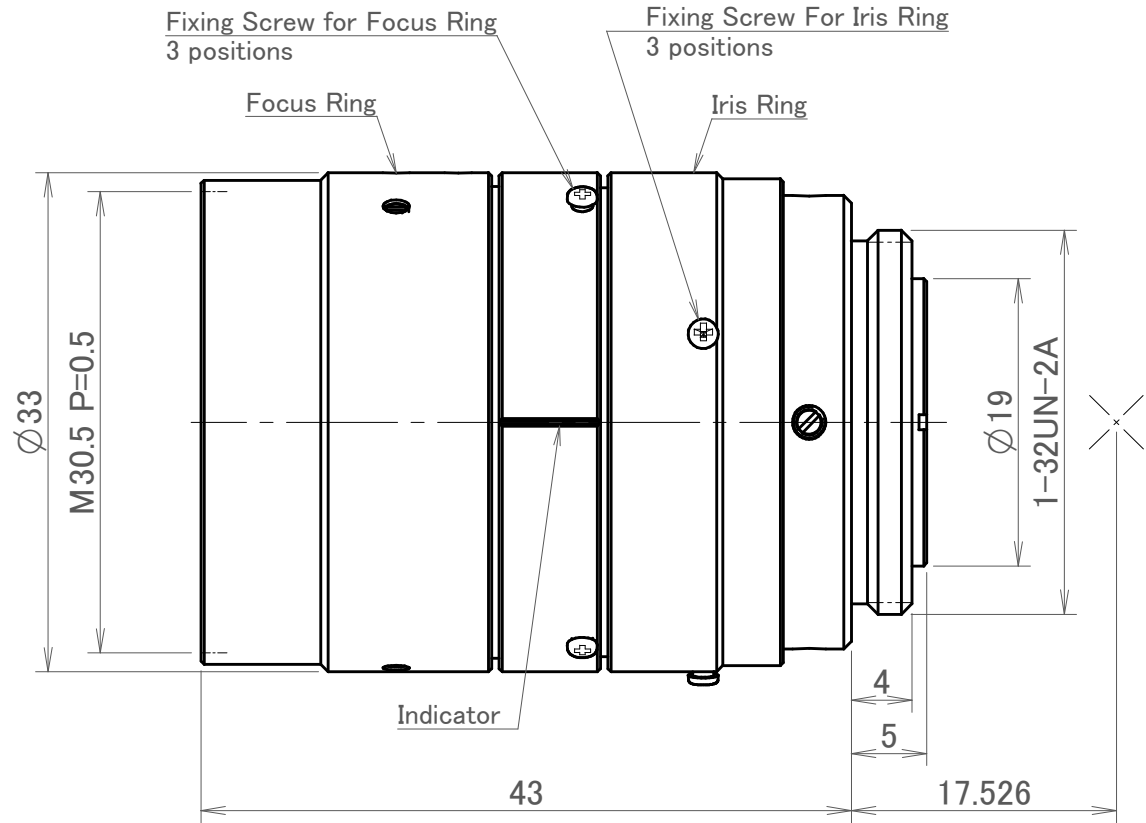
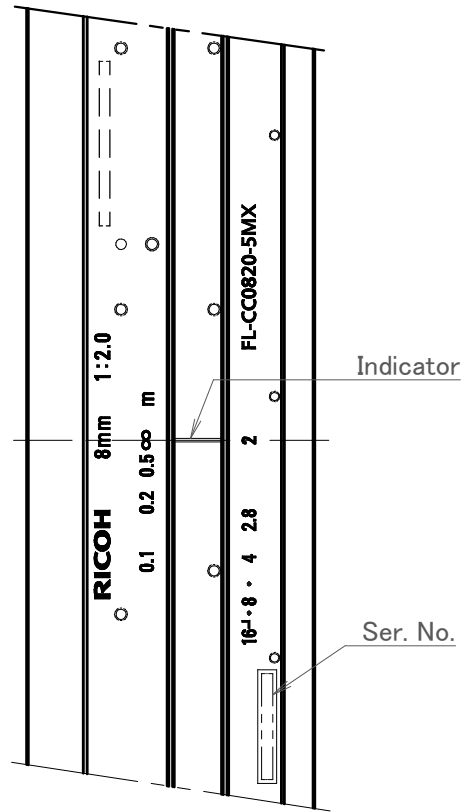

SPEC. INFO	FL-CC0820-5MX
	K66886-S001-B33
RICOH Industrial Solutions Inc. Aug.30.2019	